

## Black Gator™ I – Penetrators

The PFT™ standard line of wellhead penetrators follows traditional industry design profiles beginning with the Mini: 12-1/4" long; Mid-Size: 18-1/2" long; and the Maxi: 24-3/8" long. All of these penetrators are rated to 5000 psig, 5kV, 205A, temperatures up to 400 deg F, and incorporate PEEK™ component parts. Most penetrators are also available in CSA-approved C1D1 (explosion proof) designs.

Penetrator O.D. profiles may vary depending on the wellhead manufacturer and the amount of space available for the penetrator in a wellhead assembly. PFT™ has numerous penetrator designs that can be supplied with our new Gator Loc™\*, 2-turn make-up connection.

If one of our existing designs does not meet your needs we can design a penetrator that will meet your specific wellhead requirements.

### PEEK™ Insulator

PEEK™ is extremely well suited for all downhole applications. Depending on the material grade, PEEK™ can work continuously at 260 deg C (500 deg F). PEEK™, in comparison to molded rubber, does not take a "set" when put into compression nor is it subject to gas penetration. Combined with our oversized copper contacts, the PFT™ Black Gator™ Connector combines a longer run life with the ability to re-run components.

### Connector Body Parts

Components are carbon steel and meet NACE MRO 175 specifications. The black finish provides maximum corrosion protection as well as lubrication for the threaded components. Stainless steel components are also available.

### Threads

While we do not advocate attaching our connectors to penetrators supplied by other manufacturers, we offer several thread profiles that will mate with various penetrators. Please contact PFT™ for confirmation before purchasing.

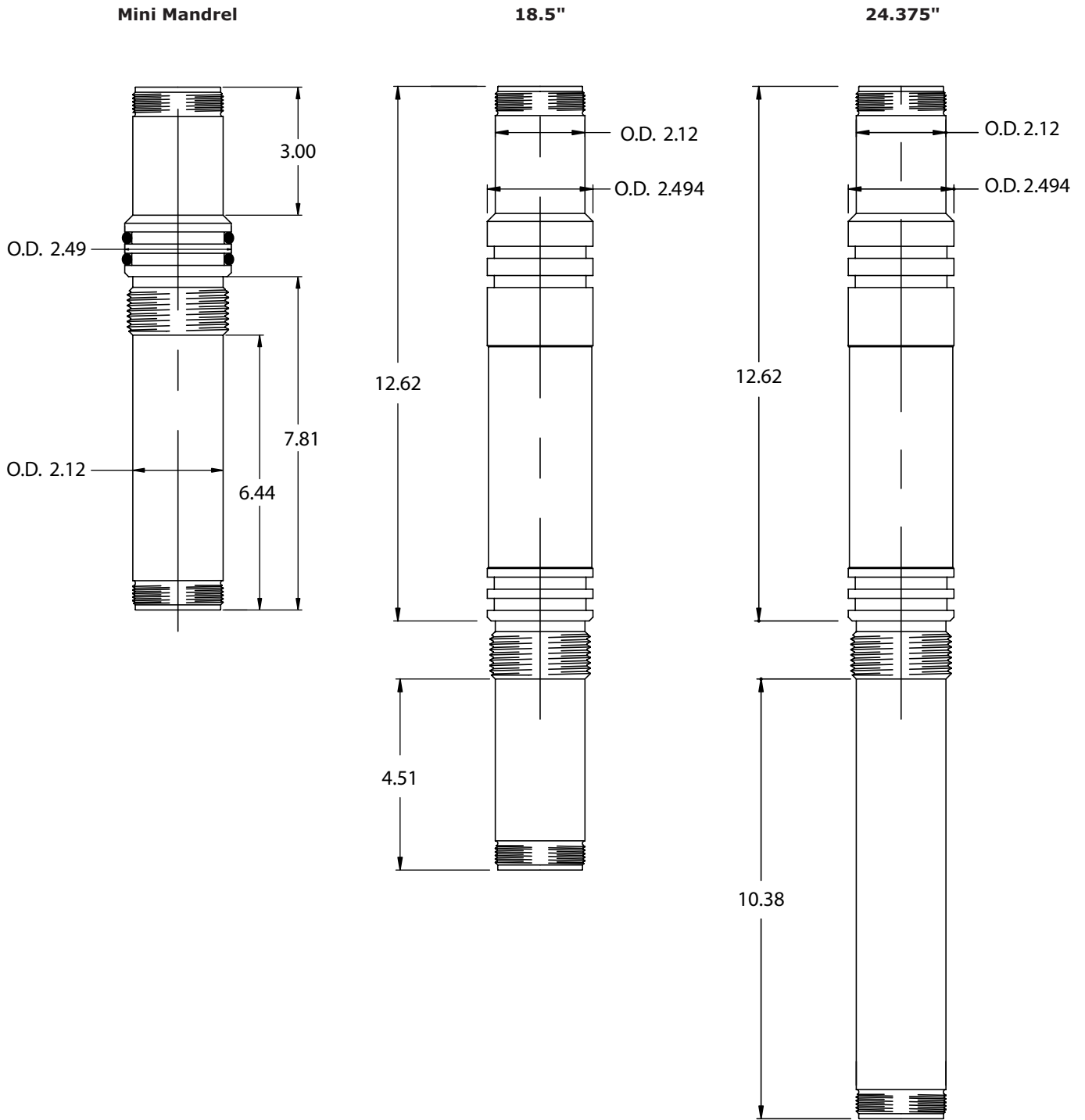

**Black Gator™ I – Penetrators**

All dimensions in inches